

**Chem-Safe™** heat exchangers are similar to our Pool-Safe products in that high performance Titanium is used for our twisted tubing for the purpose of corrosion resistance. However, a stainless steel jacket is used for long lasting operation in chemical environments where plastic may not withstand the effects of heat and petrochemicals.

Due to the superior corrosion resistance of Titanium in comparison other metals on the market today it is a smart choice for harsh chemical applications.

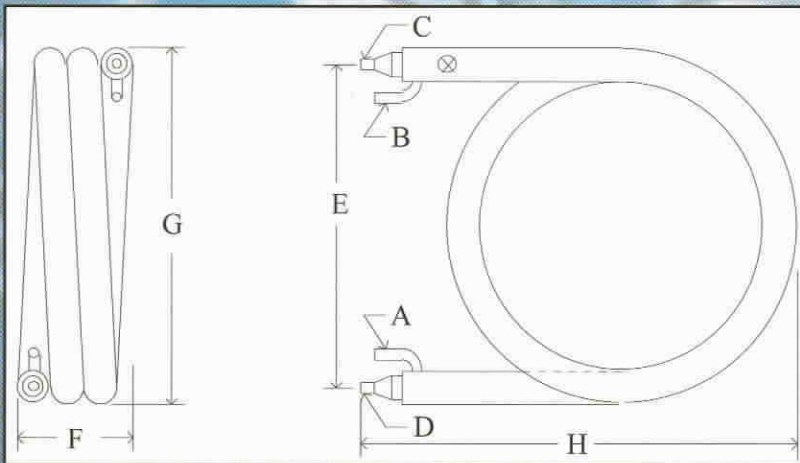

Specifications	
A :	5/8" Nom.
B :	1/2" Nom.
C :	1.25 "
D :	1.25 "
E :	16 "
F :	7 "
G :	17.25 "
H :	18.25 "
SS Volume : 141.5 in <sup>3</sup>	
TS Volume : 132.5 in <sup>3</sup>	
Dry Weight : 18.5 Lbs	

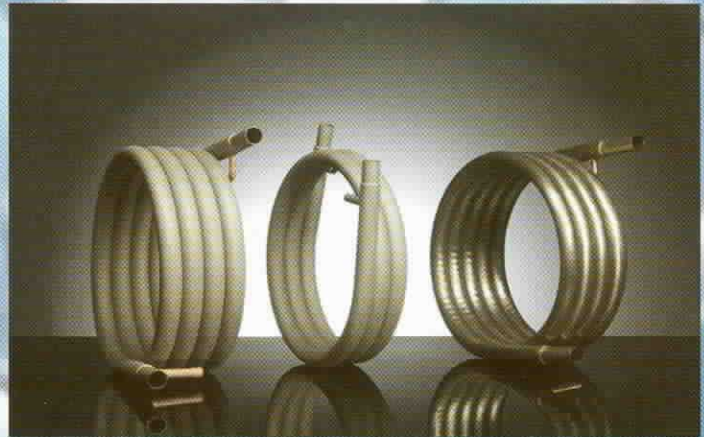